

**INSTRUCTIONS FOR INSTALLATION AND USE  
OF THE SAFETY BRAKE SYSTEM  
PRB 30 - PRB 40 - PRB 50**

A

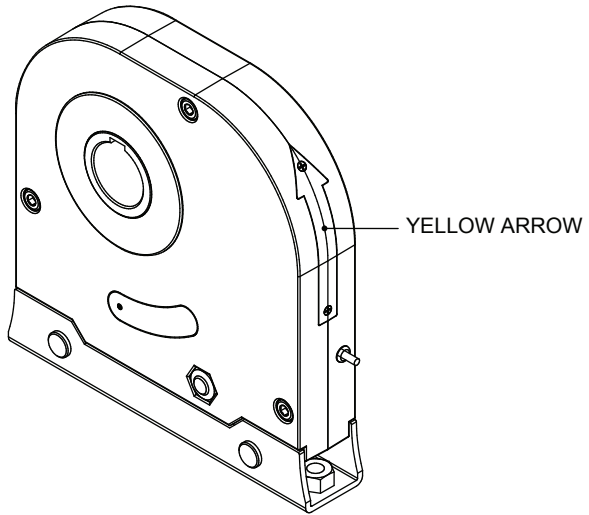

The safety brake must be installed on the shaft of the rolling shutter always in a horizontal position. Please, note that, when the rolling shutter is performing the closing operation, the shaft should rotate in the direction indicated by the yellow arrow ( see figure A ) .

---

B

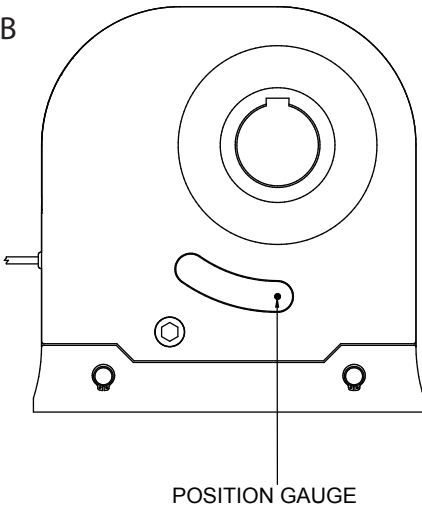

C

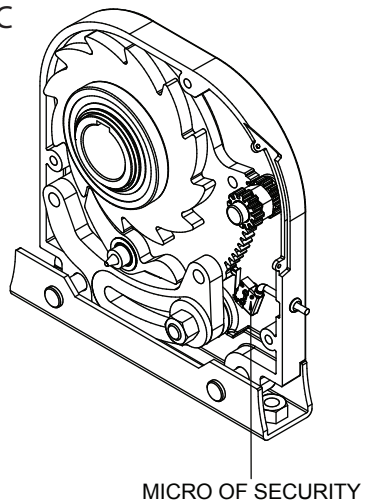

All the models of the safety break systems are supplied with the position gauge visible from the slides ( see figure B ), ready for installation and with the contact of the micro of security NC (see figure C).

---

D

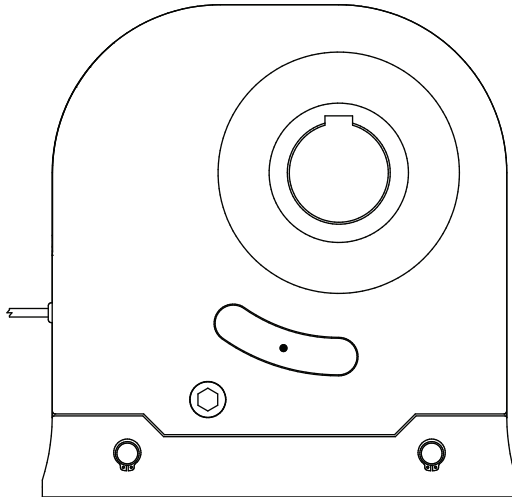

When the descent speed of the rolling shutter exceeds the preset safety threshold, the safety break system engages and stops the uncontrolled fall of the shutter. This action forces the position gauge to move. According to the weight stopped, the gauge indicates the index reached. ( see Figure D). The contact of the micro switch opens and, if connected, stops the rotation of the gear motor. In this situation, the shaft of the rolling shutter remains blocked downwards. In order to free the shaft, rotate it upwards for about  $\frac{1}{4}$  of a turn , then make the shutter go into the position of the total closure. The maneuver must be done very slowly to avoid further damages, and it ends when the shaft is free from any stress .

At this point we need to remove the cause that led to the fall of the shutter, restore its proper functioning and return the safety break system to the initial conditions through a process of resetting.

## RESET PROCEDURE

E

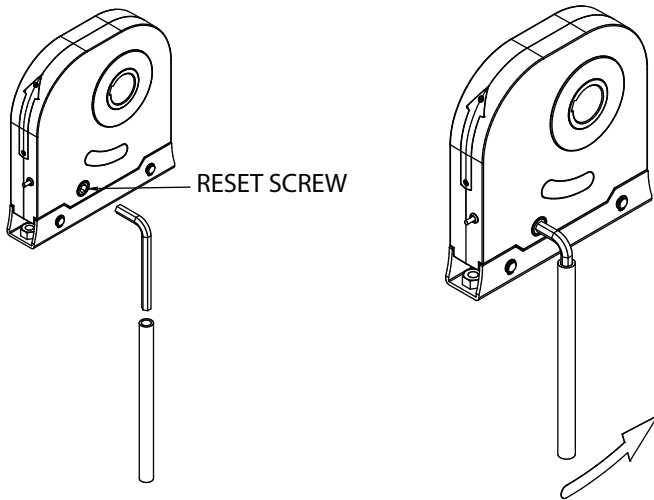

**1.** Unlock the reset screw with an hexagonal key size 10 for models PRB 40/50 and key size 6 for models PRB 30 (see fig.E) . This operation can be made easier by using a metal tube as shown in the picture.

---

F

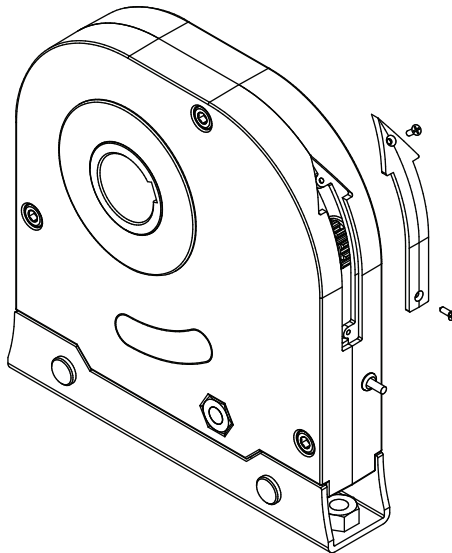

**2.** Loose the screws holding the yellow arrow-shaped cover in order to reach the hexagonal pinion (see FIG.F) .

---

G

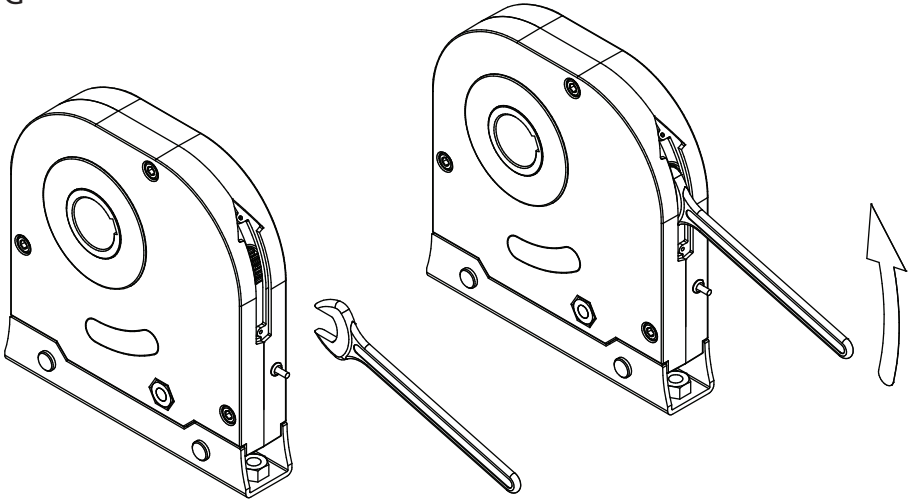

**3.** Turn upwards with a wrench size 22 for models PRB 40/50 and size 13 for the models 30 PRB (see Fig. G) in order to make the index of position return in the initial condition of operation (see fig. B).

---

H

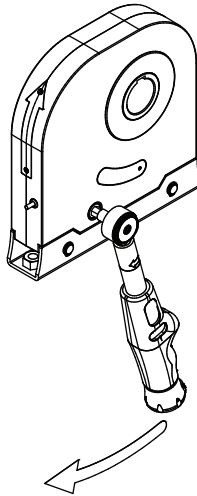

**4.** Check that the contact of the safety switch has returned to NC; put the yellow cover; tighten the reset screw back with a torque wrench in order to calibrate the tightening (see fig.H) according to data reported in the table of technical characteristics ( pages 6-7).

---

# TECHNICAL CHARACTERISTICS

TECHNICAL DATA							
MODEL		PRB 30/200	PRB 30/400	PRB 40/600	PRB 40/900	PRB 50/1200	PRB 50/1500
Max Torque	N m	600	1200	1800	2700	3600	4500
Admittable Torque	N m	200	400	600	900	1200	1500
MaxSpeed RPM	giri/1'	21	21	21	21	21	21
Shaft diameter	mm	30	30	40	40	50	50
Degree of protection	IP	65	65	65	65	65	65
Weight	kg	2,230	2,230	8,480	8,480	8,620	8,620
Positioning		horizontal only	horizontal only	horizontal only	horizontal only	horizontal only	horizontal only
Item Code		76930002	76930004	76940006	76940009	76950012	76950015
Reset screw tightening torque	Nm	15	20	15	20	25	30

MODEL	MEASURES	A	B	C	D	E	F	G
		mm	mm	mm	mm	mm	mm	mm
PRB 30		138	51	87	30,1	8	33,3	100
PRB 40		230	85	145	40,1	12	43,3	164
PRB 50		230	85	145	50,1	14	53,8	164

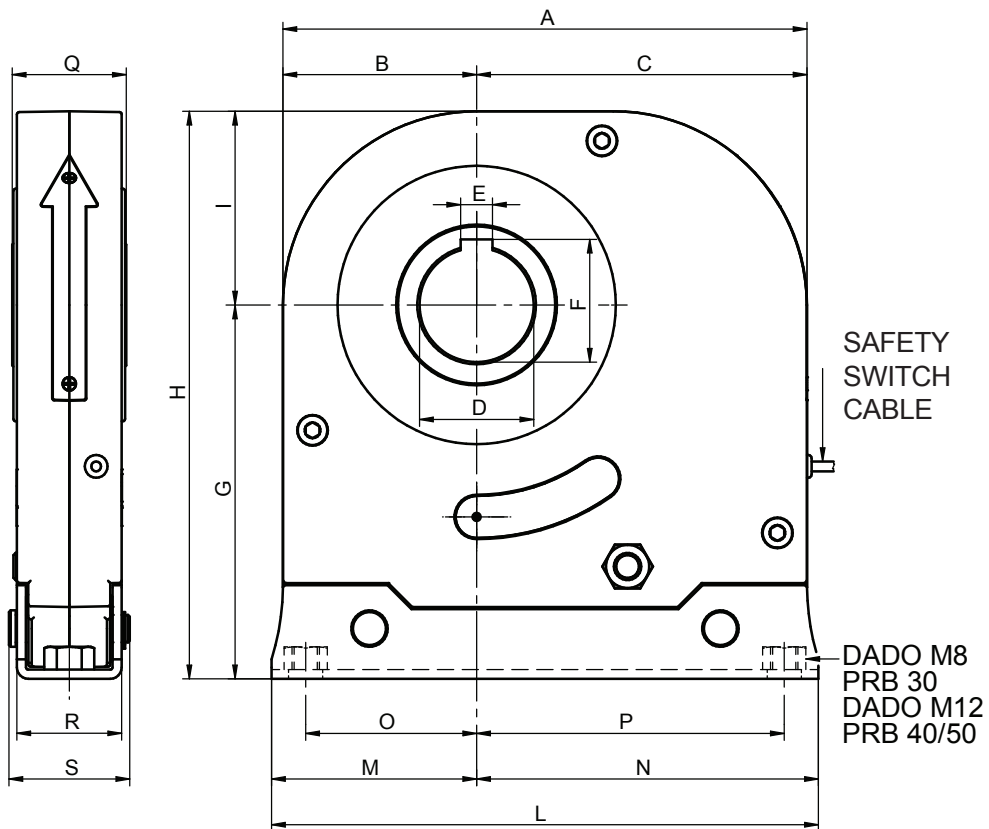

H mm	I mm	L mm	M mm	N mm	O mm	P mm	Q mm	R mm	S mm
151	51	145	54,5	90,5	45,5	81,5	36	32	37
249	85	240	90	150	75	135	50	46	53
249	85	240	90	150	75	135	50	46	53

The safety brake systems PRB 50, once engaged (in case the position index gauge exceeds the limit of 25°), can not be reset on spot and need to be replaced with the new ones. Engaged safety brake systems can be regenerated, following a special procedure, in authorized service centres.

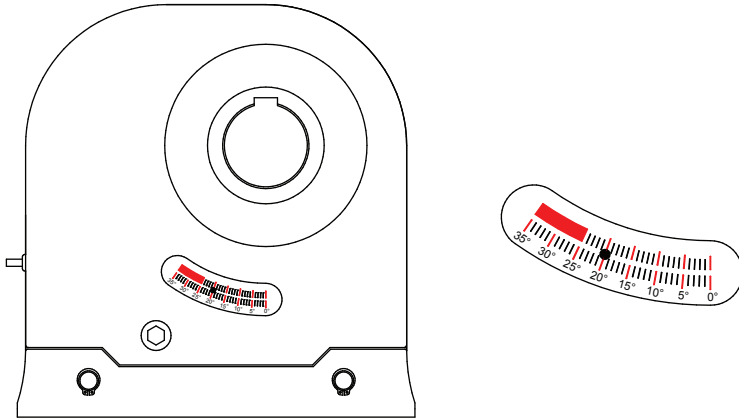

**1° CASE** – Operation of the Safety Break System with the engagement included from 0° till 25°.

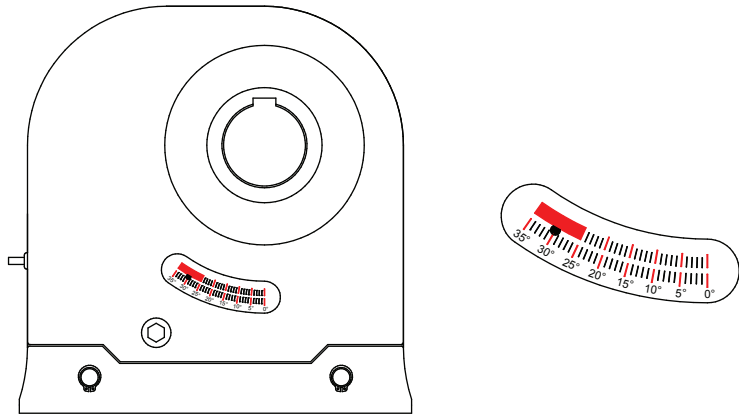

**2° CASE** – Operation of the Safety Break System with the engagement included from 25° till 35°.